

Mussana
CREAM WHIPPING MACHINES

Mussana
MONTAPANNA

Mussana
SAHNE-AUTOMATEN

www.mussana.de

Mussana
APPAREILS A CHANTILLY

Mussana
MONTADORAS DE NATA



PONY

BOY



LADY

GRANDE



DUO

Bedienungsanleitung
Operating instructions
Notice d'utilisation
Istruzioni per l'uso
Instrucciones de uso

OPERATING INSTRUCTIONS FOR

MUSSANA MICROTRONIC Cream Whipping Machine

Thank you for putting your trust in us and we congratulate you on your purchase of a **Mussana Microtronic** Cream Whipping Machine. You have acquired an absolutely top-class Cream Whipping Machine.

Please read these operating instructions thoroughly before using the machine for the first time so that you can work with it for many years, free of any trouble. The instructions explain how you operate the following types of appliances:

- ◆ PONY 2 litres
- ◆ BOY 4 litres
- ◆ LADY 6 litres
- ◆ GRANDE 12 litres
- ◆ DUO 2 x 6 litres



PONY



BOY



LADY



GRANDE



DUO

Manufacturer:
Hans Kratt Maschinenfabrik GmbH
D-68219 Mannheim

Mussana
CREAM WHIPPING MACHINES

BRIEF INSTRUCTIONS



1. Insert the mains plug of your **MUSSANA MICROTRONIC** into a suitable, contact-protected power point.
Ensure that other machines are at least 5 cm away.
2. Before your **MUSSANA MICROTRONIC** is first brought into service, it should be thoroughly rinsed with approx. 1.5 litres of cold water. Please press the manual button to remove water.
3. Fill the pre-cooled cream (with at least 30 % fat content) into the cream container.
4. Press one of the operating buttons on the panel to draw out the cream.

Manual button = The machine operates while you are pressing this button.

Continuous button = Press, the pump runs (for a maximum of 3 minutes), press again, the pump stops.

Portion button = Automatically releases the chosen portion.

5. The air regulating valve must be adjusted in such a way that the cream does not splash out.
6. We recommend the machine is cleaned daily in accordance with the cleaning instructions.
7. Please read the detailed operating instructions thoroughly.

CONTENTS LIST



A	Hints concerning the cream	Page 1
B	Reference the machine	Page 2
C	Installing the machine and the mains	Page 2
D	Bringing into service	Page 3
E	Explanation about operational elements	Page 4
F	Setting the air regulating valve	Page 5
G	Cleaning instructions	Page 6
H	Disinfecting	Page 7
I	Care and maintenance	Page 7
J	Table of faults	Page 8
K	Technical data for Europe	Page 9
L	Technical data for USA and Canada	Page 10

A HINTS CONCERNING THE CREAM



Even the best cream whipping machine can only provide the best service if you use the right cream. Please take into consideration that cream is a natural product which is subject to different variations, such as the seasonal composition of the dairy animals' feed.

Generally the use of fresh cream with a fat content of between 30 and 35 % is recommended. When using long-life cream, it is possible to have longer durability but it is recommendable to purchase well-known products as not all long-life creams whip up satisfactorily.

Please Note:

A complete cold chain from the dairy to the end user must be absolutely guaranteed. Even a brief increase in temperature can destroy the cream culture and make whipping impossible.

Cream can be sweetened with any sugar in liquid form (pure sugar or liquid sweetener). If you use crystal sugar, please stir well into the cream.



B REFERENCE THE MACHINE



Every Mussana Microtronic Cream Whipping Machine is fitted as standard with a pre-set **portion control mode through sensor buttons** and equipped with **intensive refrigeration up to the decorating nozzle**.

Our product conforms to the relevant **EC standards**.

The machine has been tested according to **DIN 10507** for cream whipping machines. Each appliance carries an individual **series number** for identification of your machine.

C INSTALLING THE MACHINE AND THE MAINS

The Mussana Microtronic Cream Whipping Machine should be installed free-standing on a firm, level surface. The distance between its side to other objects or walls should be at least 5 cm, so that the heat removal functions perfectly. If an appliance such as a deep fryer or oven, which produces heat, stands next to the cream whipping machine, the distance away should be greater.

Please Note:

Too small a distance between them causes a reduction in the refrigeration performance and extra burden on the refrigeration unit.

The appliance can be connected to any correctly installed contact protected power point with 230 Volt (50 Hz) alternating current. A 6.3 amp fuse is located on the in-built electronic platform.

For USA and Canada:

The appliance can be connected to any correctly installed contact protected power point with 110 Volt (60Hz) alternating current. A 10 amp. fuse is located on the in-built electronic platform.



D BRINGING INTO SERVICE



1. Insert the plug into the suitable contact protected mains point. The refrigerator and ventilator start up automatically. The red control light illuminates first of all on the operating panel.
2. Before using for the first time, the machine should be cleaned, following our cleaning instructions in point (H).
3. After about 20 minutes, the cream whipping machine has cooled down. This will be indicated by the green light diode (operating situation).

Please Note:

Never fill the cream directly into the stainless steel inner container!

4. Fill the required amount of pre-cooled cream into the cream container.
5. Place the air regulating valve to position 2 - 3 and press the manual button until the cream comes out of the decorating nozzle. If the whipped cream does not meet your expectations, please read further under section E (explanation of the air regulating valve).

Should the pump not immediately absorb the cleaning liquid or the cream, unscrew and remove the complete air regulating valve and apply drops of water directly into the pump, after which the pump can absorb again.



E EXPLANATION ON OPERATION ELEMENTS

MANUAL BUTTON

Pump runs for as long as the button is pressed.
(in the cleaning-program active)

OPERATING POSITION

red = too warm

green = OK

(in the cleaning-program, the green lamp blinks 10 minutes)

yellow = too cold

LONG-LASTING BUTTON

Press Button = pump on
press again = pump out

Maximum running time 3 minutes

(Cleaning-intervall-irrigation in the cleaning-program)

PORTION-BUTTON

(in the cleaning-program blocked)

about 18 grams

about 30 grams

about 40 grams

about 60 grams

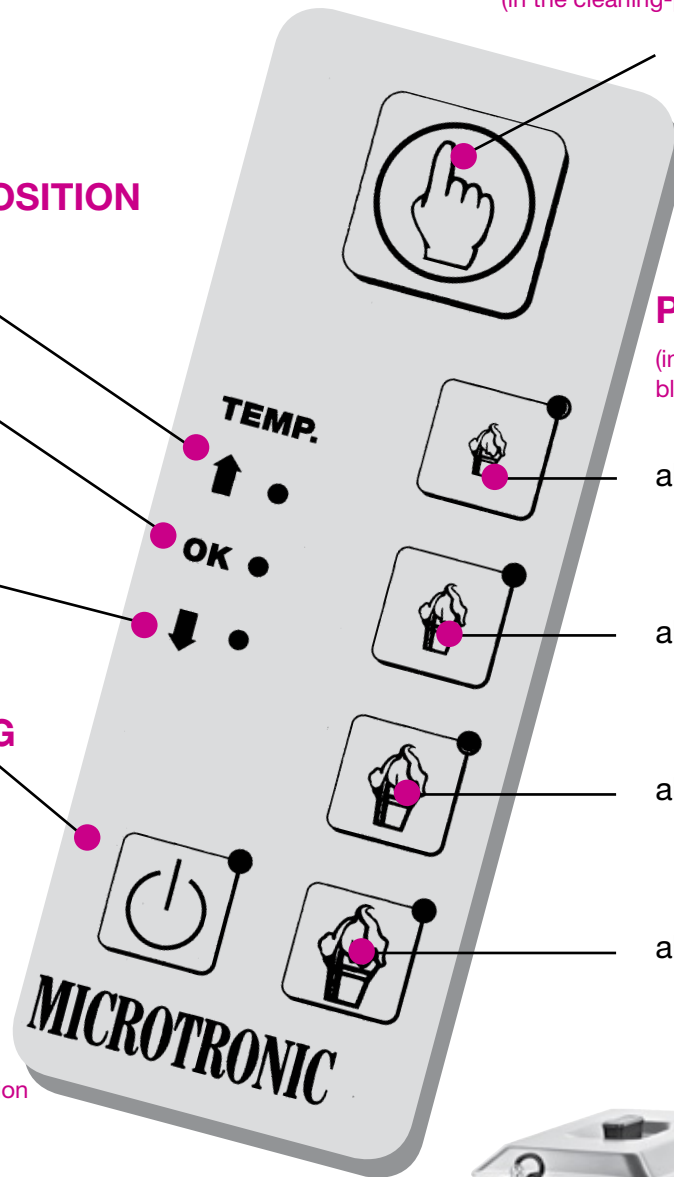

NEW

Cleaning-program-button with interval-irrigation and refrigeration-interruption (10 minutes)



Cleaning-program-button



F SETTING THE AIR REGULATING VALVE



1. The setting of the air regulating valve depends on the fat content of the cream and the desired consistency.
2. Cream with a higher fat content e.g. over 32 % needs a lower air supply. Cream with less fat content e.g. up to 30 % requires a higher air supply.

Please Note:

It is recommended to begin with a smaller scale setting between 2 and 3 as the cream turns to butter too quickly with too high an air supply and the machine must then be completely cleaned.

3. If the cream is too runny, the air regulating valve must slowly be opened above 2 and 3 until the required consistency is reached. If the cream splashes out or is whipped too stiffly, the air regulating valve must be closed tighter.
4. The air regulating valve (upper and lower part) must always be clean. If the air regulating valve is dirty, the cream will not be whipped correctly as not enough air can mix with the cream.
5. It is recommended that the cream be mixed well every 3 - 4 hours in the cream container so that the fat content of the cream is always evenly distributed.



G CLEANING INSTRUCTIONS

Please Note:

For reasons of hygiene, your MUSSANA Microtronic should be cleaned daily. Please only use the MUSSANA disinfectant to clean and disinfect as this product guarantees thorough cleaning of the machine, even under the strict pre-requisites of the DIN 10507 standard for cream whipping machines.

1. Please press the cleaning-programm-button (green light blinks and the refrigeration is interrupted for 10 minutes).
2. The cream-container with app.1,5 l hot waters filling and with operating the interval- button pumping through the machine (the machine runs approximately 1,5 minutes and switches 8 times on and stops again).
3. The cream-container with ca. 1,5 l possible hot water (50° until 80° CS) filling and two dosing head filling MUSSANA-MIKROCLEAN-DESINFektionsCLEANER, (app.40ml) giving inside.

Caution: Always use the dosing head provided!

The cleaning-solution also with operating the interval-button  pumping through the machine.

Remind: a foaming of the cleaning-solution is normally and don't impair the cleaning-process.

4. The cream-container with clear, cold water (app. 1,5 to 2 l) filling and with operating the interval-button pumping  through the machine again.
5. Unscrew the garnish tube (upper and lower part) and the air regulation valve, check them for cleanliness and, if necessary, clean them under warm water again.
6. The machine with a moist rag cleaning and with one dry rag drieving.
7. After app. 10 minutes starts the refrigeration automatically and the machine is operational again.

Respect: The refrigeration always should switch on remains, because the germ growth is at 4° C reduced to zero. (The machine has a very low Energy-consumption)

8. If the machine is a longer time (1 weeks) out of working so, please the mixing-system dismantles and dries.
9. Sould during the cleaning-process the red control-lamp lighting, no breakdown is available so. This is only a reaction from the appliction of the hot water. After a short waiting becomes through the green control-lamp the normal business-condition again is showing.



H DISINFECTING



For machines without automatic cleaning!

In order to increase the effect of disinfecting, the remainder of the cleaning liquid should be left overnight once a week after the main washing process (in point G 3) in the pump and the whipping system.

The next morning, before use, pump away the solution and rinse with about 3 litres of clear, cold water. The disinfecting process should also be carried out after a long period of non-use.

I CARE AND MAINTENANCE

For machines without automatic cleaning!

1. From time to time the stainless steel inner container should also be cleaned. To clean the inner container, remove the mains plug and let the appliance defrost. Use hot water with washing-up liquid and finally dry the inner container thoroughly.
2. Never rub the outer coating with rough objects otherwise the surface scratches. A standard stainless steel care product can be used to remove any pieces of fat residue which have become stuck.
3. Occasionally an inspection of the sealing rings, especially in the whipping system and inlet pipe, should be carried out.
4. Any other maintenance to the machine is not required, other than normal cleaning and disinfecting.
5. In case of faults which cannot be resolved by following the table of faults, please contact your appropriate specialist dealer.



J TABLE OF FAULTS

Please note:

Opening the machine's cover is only permitted after agreement in advance with the proper specialist dealer. Improper opening can lead to the damage of the electronic components inside the machine.

Please Note:

Before opening the machine's cover, always pull out the mains plug!

Fault	Advice
1. The cooling machine is not starting up on the first use.	Leave the machine about 20 mins without mains connection so that pressure can be reduced. Then re-connect to mains.
2. The pump is not sucking up any water or cream	The pump is dry. Pour a little liquid through the opening of the air regulating valve, after which the pump will work independently.
3. Cream is turning to butter in the whipping system	The cream is too warm and/or the air regulating valve is on too high a setting. Dismantle and clean the whipping system. Re-assemble all parts and make an adjustment to the air setting. Pre-cool the cream well.
4. The cream is too runny.	Turn up the air regulating valve if the air regulating valve is blocked, dismantle into 3 parts and clean.
5. During the cleaning process, the red control diode illuminates.	The temperature reader reacts when hot water is used. After cleaning, the green control diode will light up again after a short pause.
6. During normal operation, the red cooling diode illuminates.	No self-help is possible. Please contact your specialist dealer.
7. Failure in functioning of one or several buttons on the operating panel.	No self-help is possible. Please contact your specialist dealer.



Voltage/Cycles:	230 V / 50 Hz	Amount of cooling means:	
Energy intake:	approx. 500 W	PONY	= 70 gram
Fuse:	T 6.3 A (on the small metal panel)	BOY	= 85 gram
Refrigerant:	R 134 a	LADY	= 90 gram
		GRANDE	= 115 gram
		DUO	= 125 gram

• Manufactured in accordance with EMVG • Tested according to DIN 10507 • Tested in accordance to GS

If you follow the prominent instruction manual exactly, you will work long time undisturbed with the machine. Guarantee - and liability falls, that appear on the basis of an improper service, are principle excluded. Technical alterations reservations. Works in the inside of the appliance are allowed to only through the manufacturer, his customer service or a similarly qualified person enforced becomes. If the main lead of the appliance is damaged, it must be replaced with one of the aforementioned persons.

Electric-plans for cream-whipping machines Microtronic until 31.12.2001, Nr. 499901

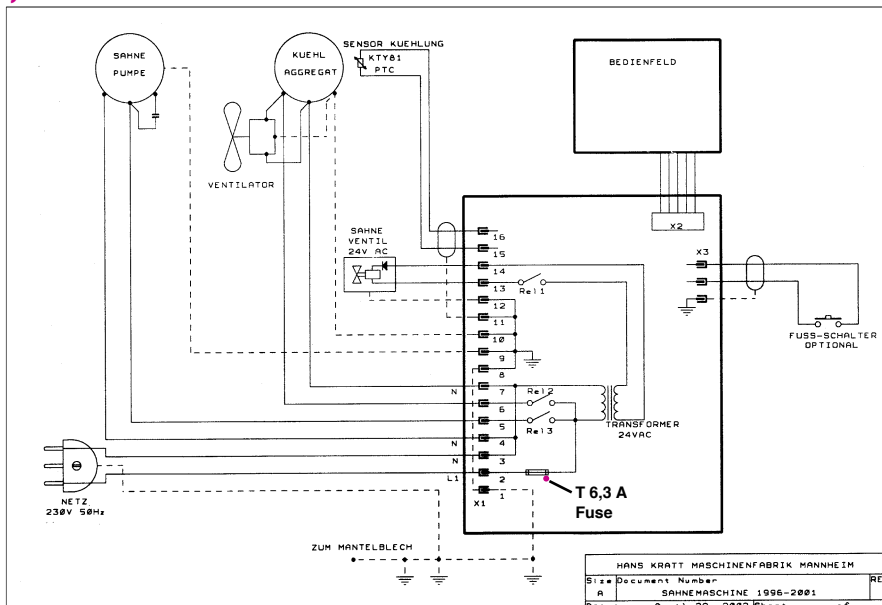

Electric-plans for cream-whipping machines Microtronic from 01.01.2002, Nr. 500002

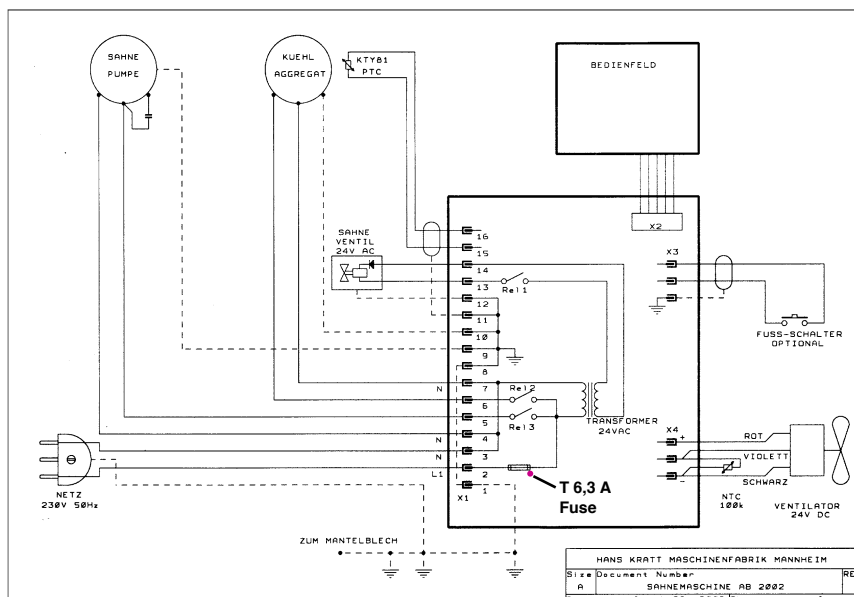

Voltage/Cycles:	110V / 60 Hz	Amount of refrigerant:	
Energy intake:	approx. 1000 W	PONY	= 2,469 ounces
Fuse:	T 10 A (on the small metal panel)	BOY	= 2,998 ounces
Refrigerant:	R 134 a	LADY	= 3,175 ounces
		GRANDE	= 4,056 ounces
		DUO	= 4,409 ounces

• Manufactured in accordance with EMVG • Tested according to DIN 10507 • Tested in accordance to GS • Tested ETL/NSF-ETL

If you follow the prominent instruction manual exactly, you will work long time undisturbed with the machine. Guarantee - and liability falls, that appear on the basis of an improper service, are principle excluded. Technical alterations reservations. Works in the inside of the appliance are allowed to only through the manufacturer, his customer service or a similarly qualified person enforced becomes. If the main lead of the appliance is damaged, it must be replaced with one of the aforementioned persons.

Electric-plans for cream-whipping machines Microtronic until 31.12.2001, Nr. 499901

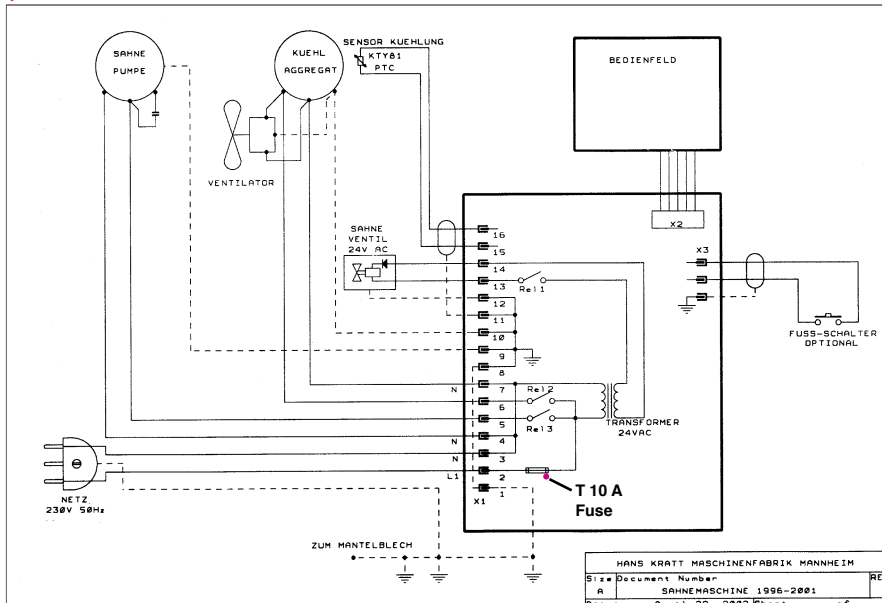

Electric-plans for cream-whipping machines Microtronic from 01.01.2002, Nr. 500002

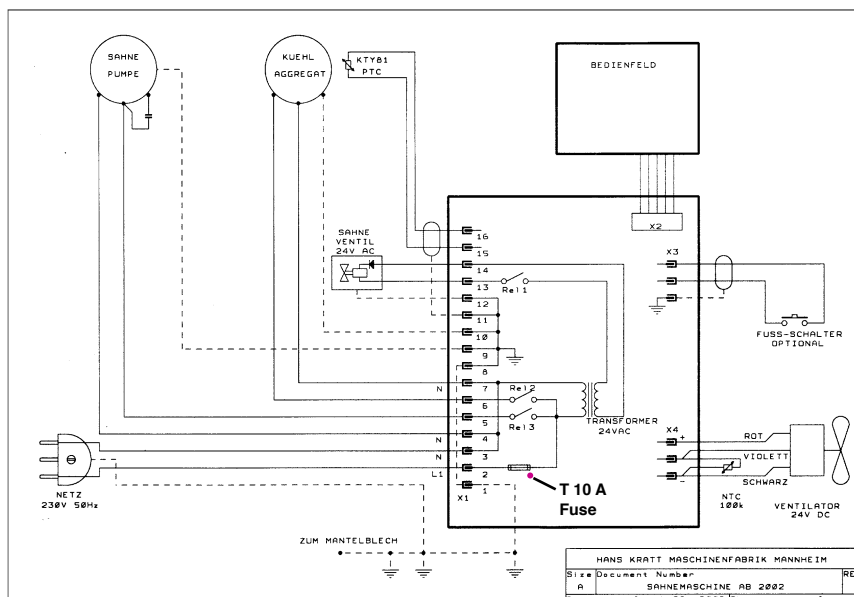

English



SPARE PART

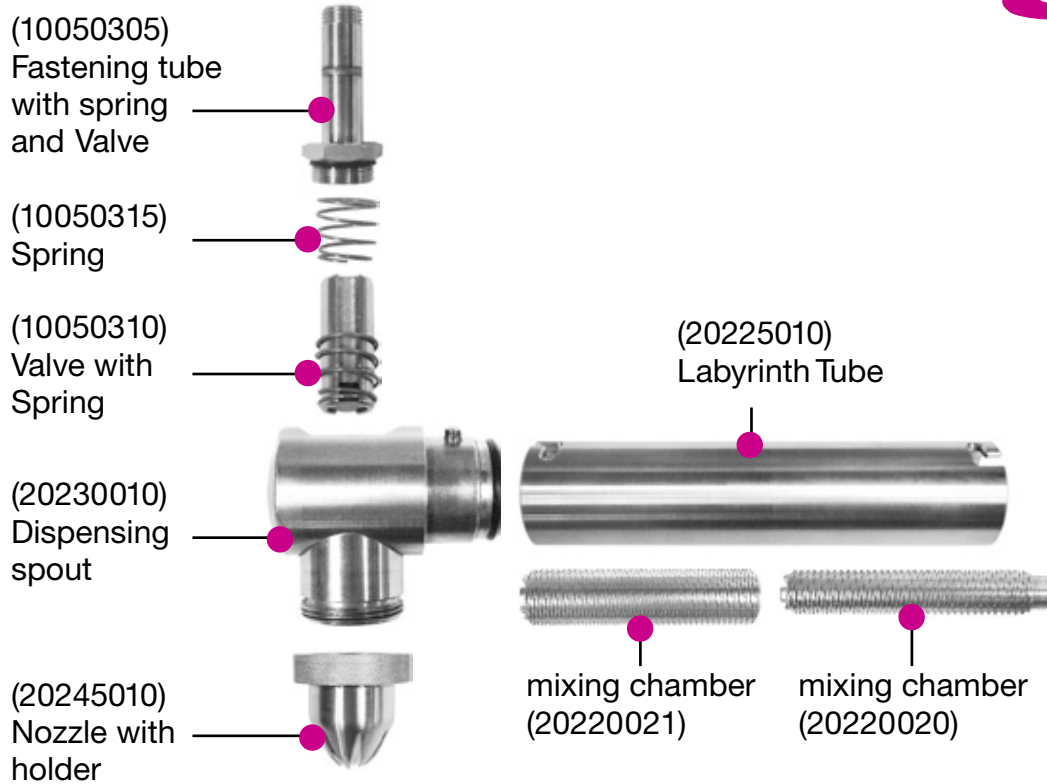

- suction tube
- Ø 8 Pony + Boy (20240660)
 - Ø 10 Pony + Boy (20240661)
 - Ø 8 Lady 2001 (20240665)
 - Ø 10 Lady 2001 (20240666)
 - Ø 8 Duo + Grande 2001 (20240670)
 - Ø 10 Duo + Grande 2001 (20240671)
 - Ø 8 Lady + Grande 2002 (20240667)
 - Ø 10 Lady + Grande 2002 (20240668)

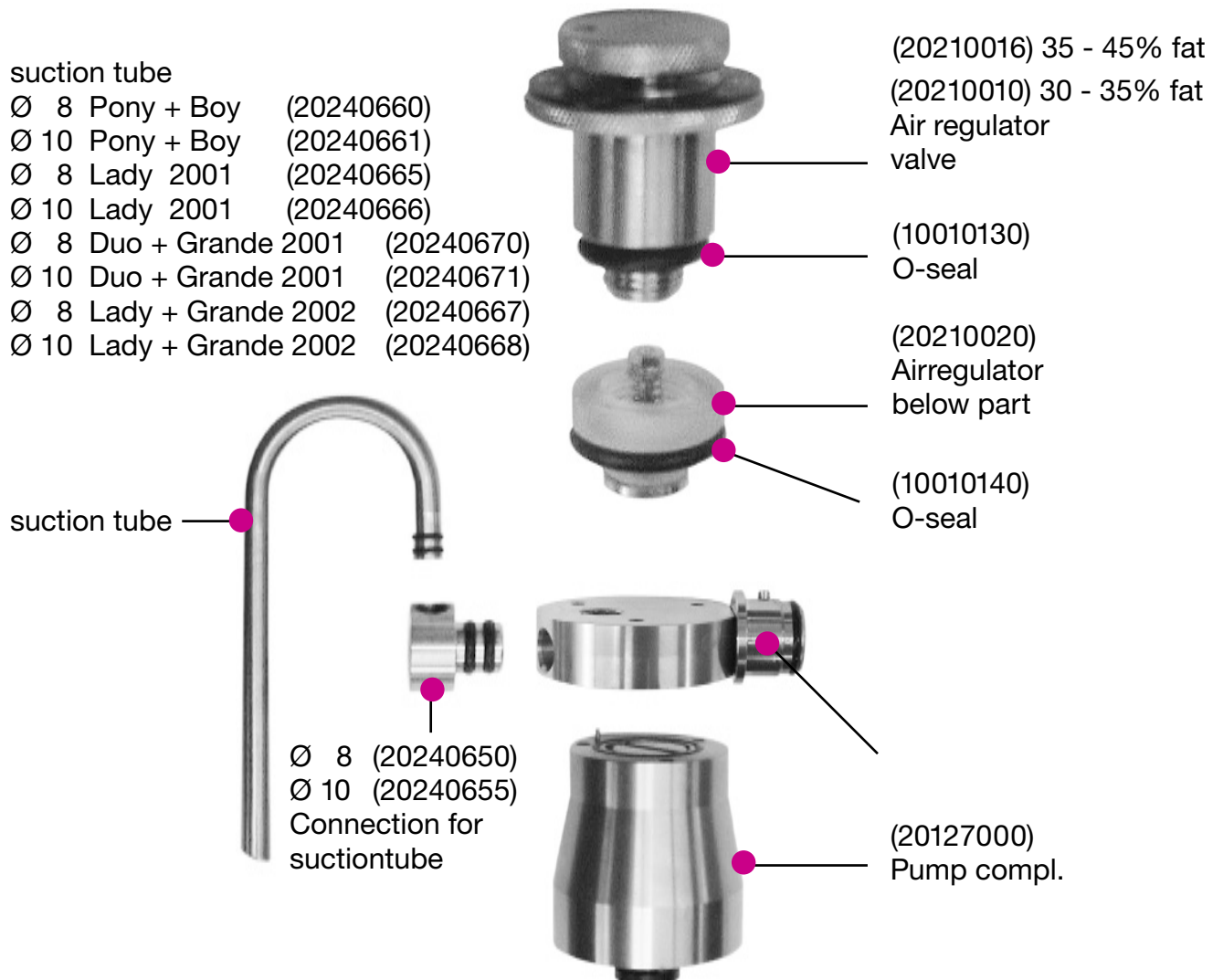



www.mussana.de